

• SPECIFICATION •

• 4799 - POT FILLER WITH LEVER HANDLES

- Handcrafted in the UK
- 1/4 turn ceramic disc flow control
- Vernier insert for accurate handle alignment
- Unique handle construction with integral bearing ring
- Fully Extended Reach 605mm
- Mounting wall plugs/screws and plate supplied
- Concealed wall fixings

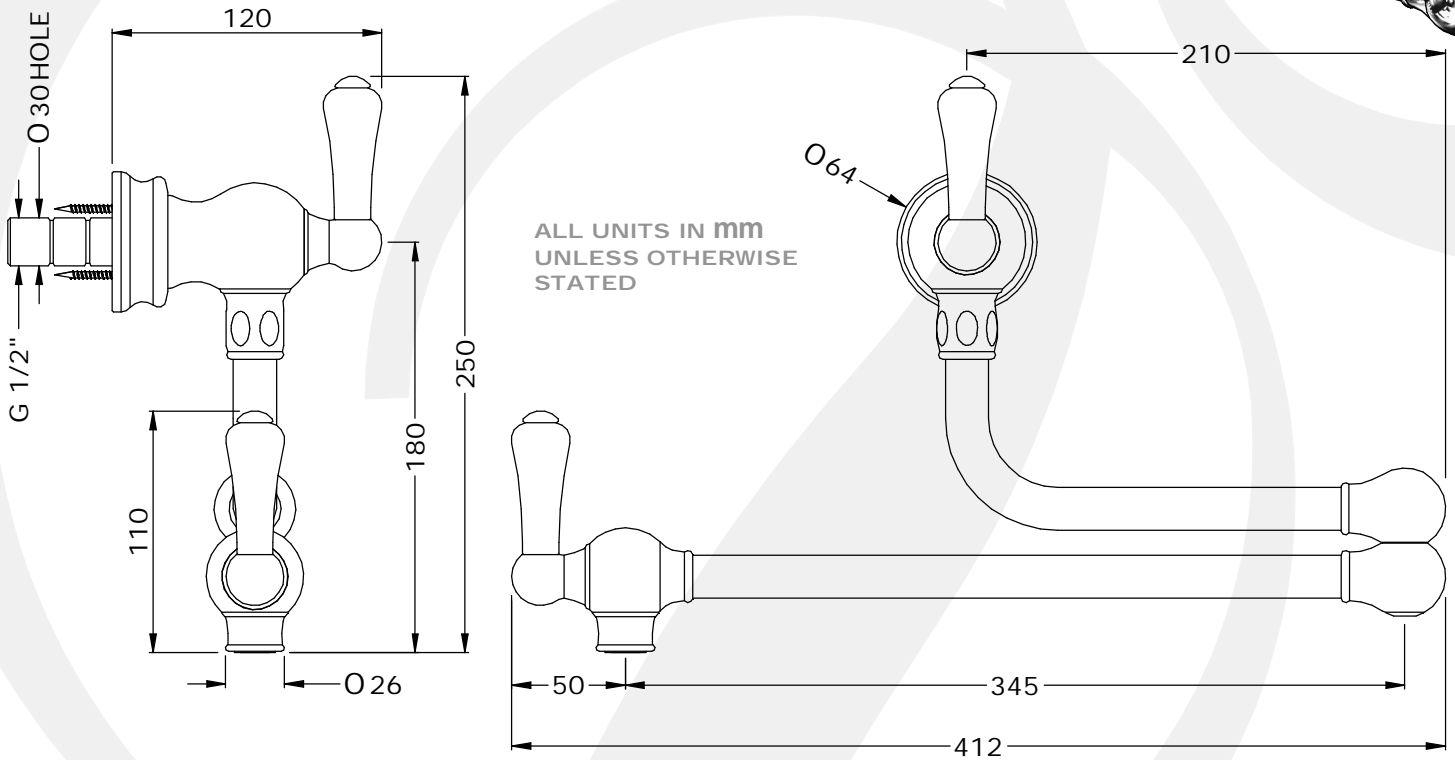
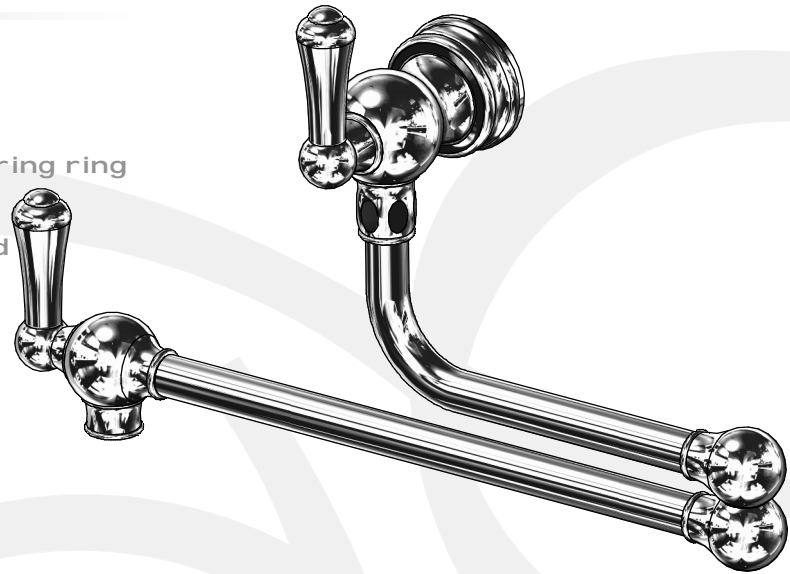

Available Finishes:

- Chrome
- Nickel
- Pewter
- Polished Brass
- Satin Brass
- Aged Brass
- Gold
- English Bronze

• Temp Range:
Min 1°C / 34°F
Max 70°C / 158°F

• Recommended
Working Pressure:
Min 1bar / 15psi
Max 5bar / 75psi

• Packed Weight:
3.15 kg

Available Options:

- Matching soap dispensers

Flow Rates:
• 1 Bar: 4.4 L/Min
• 2 Bar: 7.2 L/Min
• 3 Bar: 8.1 L/Min